

Product:

Compact Seal - Automotive Water Pump Seal

The compact seal for automotive water pump applications has a proven history of high quality field performance.

The sealing materials made of Eagle Industry's proprietary carbon components and ceramics provide high resistance to heat, wear and corrosion with an excellent sealing performance.

Operation conditions:

Item	Range	Unit
Medium	Coolant / water solution	[-]
Coolant Mixture	40 - 60	%
Pressure - nominal	0 to 0,2	MPa.g
Pressure – peak	0 to 0,3	MPa.g
Temperature - nominal	-20 till +120	°C
Temperature - peak	-40 till +140	°C
Speed - nominal	0 - 7.000	Min ⁻¹
Speed – peak	12.000	Min ⁻¹
Sliding materials	Hard Carbon / SiC	[-]
Elastomer materials	HNBR	[-]

Assembly dimensions:

Item	Range	Unit
Shaft diameter	12	mm
Shaft roughness	6,3	µmRz
Shaft hardness	>50	HRC
Bore diameter	30	mm
Bore roughness	1,6	µmRa
Total height	13	mm
Mounting depth	5,5	mm



CS 1230

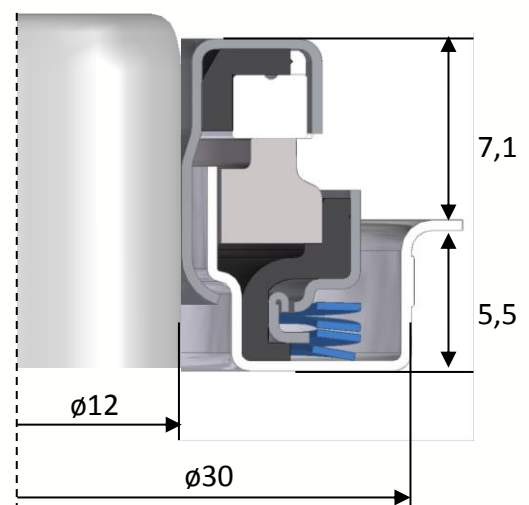

All technical specifications are based on extensive tests and our many years of experience. The diversity of possible applications, however, means that they can serve only as guide values. We must be notified of the exact conditions of application before we can provide any guarantee for a specific case. This is subject to change.

Developing small things that make a big difference.